



## LED Light Kit Installation Instructions

Covers Parts #8095

### Kit Contents:

- LED lighting module
- Distribution block
- Distribution block mount
- Accessory distribution block mount (see *Installation Note*)
- LED light bar
- LED rock light harness assembly
- LED headlight harness assembly
- LED tail light harness assembly
- 4-in-2 wire harness
- 2.6x8mm button-head cap screws (2)
- 2.5x15mm cap screws (2)

- 2.5x6mm cap screws (2)
- Zip ties (9)

### Tools required:

- 2.0mm hex wrench
- 1.5mm hex wrench
- Side cutters (to trim zip ties)



### CAUTION: RISK OF INJURY!

Always wear eye protection when using motorized tools. Use care with hobby knives, tapered reamers, and other cutting tools as they are extremely sharp and can cause severe injury, deep cuts, and/or punctures.

### LED Lighting Module Installation (Fig. 1):

1. Install the LED lighting module (A) on the left chassis floor pan. Secure with the 2.5x15mm cap screws (2).
2. Remove the screws from the receiver box cover and wire clamp; remove the cover and clamp (B).
3. Remove the two 3x10mm countersunk cap screws from the battery tray (C).
4. Lift up the battery tray and route the red wire (male connector) from the LED lighting module to the right side of the chassis, between the two T-Lock servos, and through the hole in the receiver box. Plug the connector into channel 1 of the receiver (D). **Note:** The connector can be plugged into any non-telemetry channel on the TQi receiver.
5. Apply an additional bead of silicone grease (Traxxas part #1647, sold separately) to the wire clamp. The grease will improve sealing. Reinstall the clamp and screws.
6. Make sure the o-ring is properly seated into the groove in the receiver box so that the cover will not pinch it or damage it in any way.
7. Install the cover and screws. Inspect the cover to make sure the o-ring seal is not visible.
8. Reinstall the screws in the battery tray.
9. Connect the black wire (red female connector) from the LED lighting module to the red wire (male connector) exiting the XL-5 HV electronic speed control.

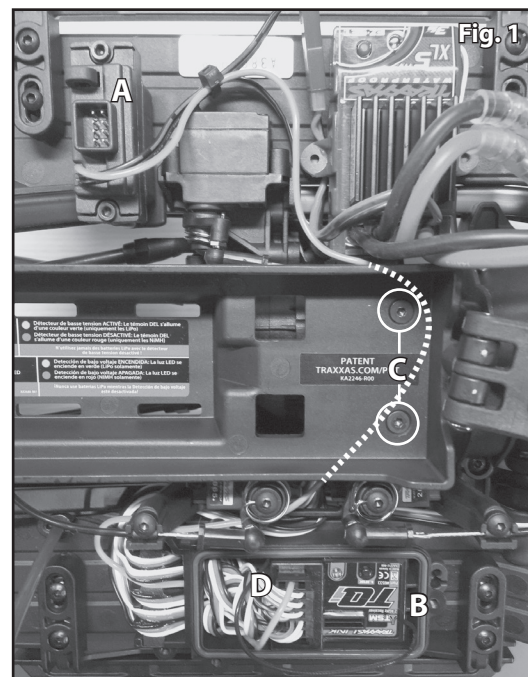

### Body disassembly (Fig. 6):

1. Remove the headlights (E), tail lights (F), fender flares (G), inner fenders (H), and rock light covers (I). You do not need to remove the spare tire carrier assembly from the body; only remove the two 4x5mm screw pins (J) that attach the rear inner fender support to the tire carrier assembly (see *Assembly Diagram on the reverse side*).

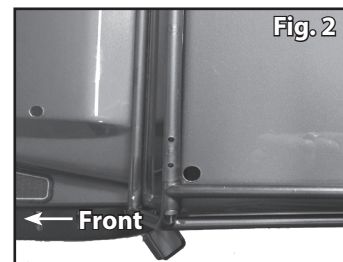

### LED Light Installation (Fig. 7):

1. Install the LED light kits (see the *Wiring Diagram on the reverse side*). The headlights, tail lights, and rock lights install as assemblies using the same hardware as the original assemblies. When installing the rock lights, note where the light string begins and ends in the wiring diagram. Do not overtighten the screws that fasten the rock lights to the inner fenders. Hand tighten these screws.
2. When installing the LED light bar, use a body reamer or a cutting bit on a rotary tool (such as Dremel®) to cut a small hole in the front left corner of the roof of the vehicle body (Fig. 2). DO NOT use a drill bit as it will catch in the body and tear it. The hole or slot needs to be large enough to pass the connector for the light bar through the body.

**Note:** It is important to cut the hole in the correct location or the light bar will not mount correctly. Secure the light bar to the roof rack using the 2.5x6mm cap screws.

3. Reinstall the inner fenders and fender flares (hand tighten the screws in the fender flares to avoid distorting or damaging the parts).
4. Use zip ties to secure all wiring and connectors to the body in the locations provided (Fig. 3).  
**Note:** Some harness assemblies may include extra connectors for adding optional accessories.

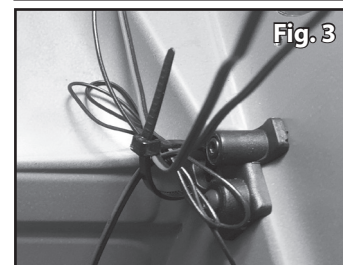

### Distribution Block Installation

1. Remove the 2.5x6mm cap screw and the 3x10 mm button-head screw from the driver side (left side) mirror retainer. Replace the mirror retainer with the included distribution block mount (K) and secure the mount and side mirror with the two removed screws as shown in Fig. 4.
2. Plug the connectors from the LED light wire harnesses into the ports of the distribution block (L). Match the color band on the wire harnesses with the corresponding color of each port indicator on the distribution block (white for headlights, red for tail lights, yellow for roof light bar and rock lights).
3. Use the included 2.6x8mm button-head screws to secure the distribution block to the mount (Fig. 4).

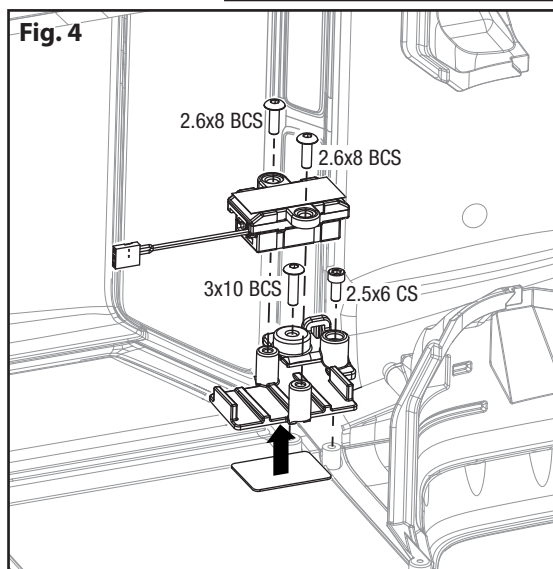
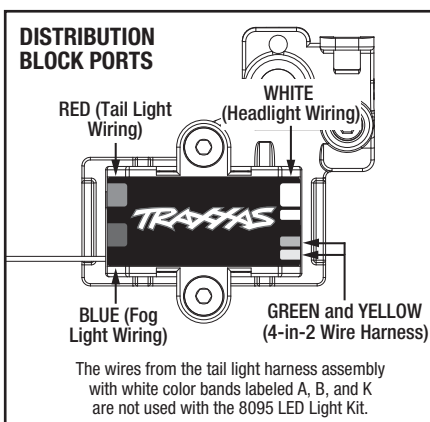

# Assembly Diagram

Fig. 6

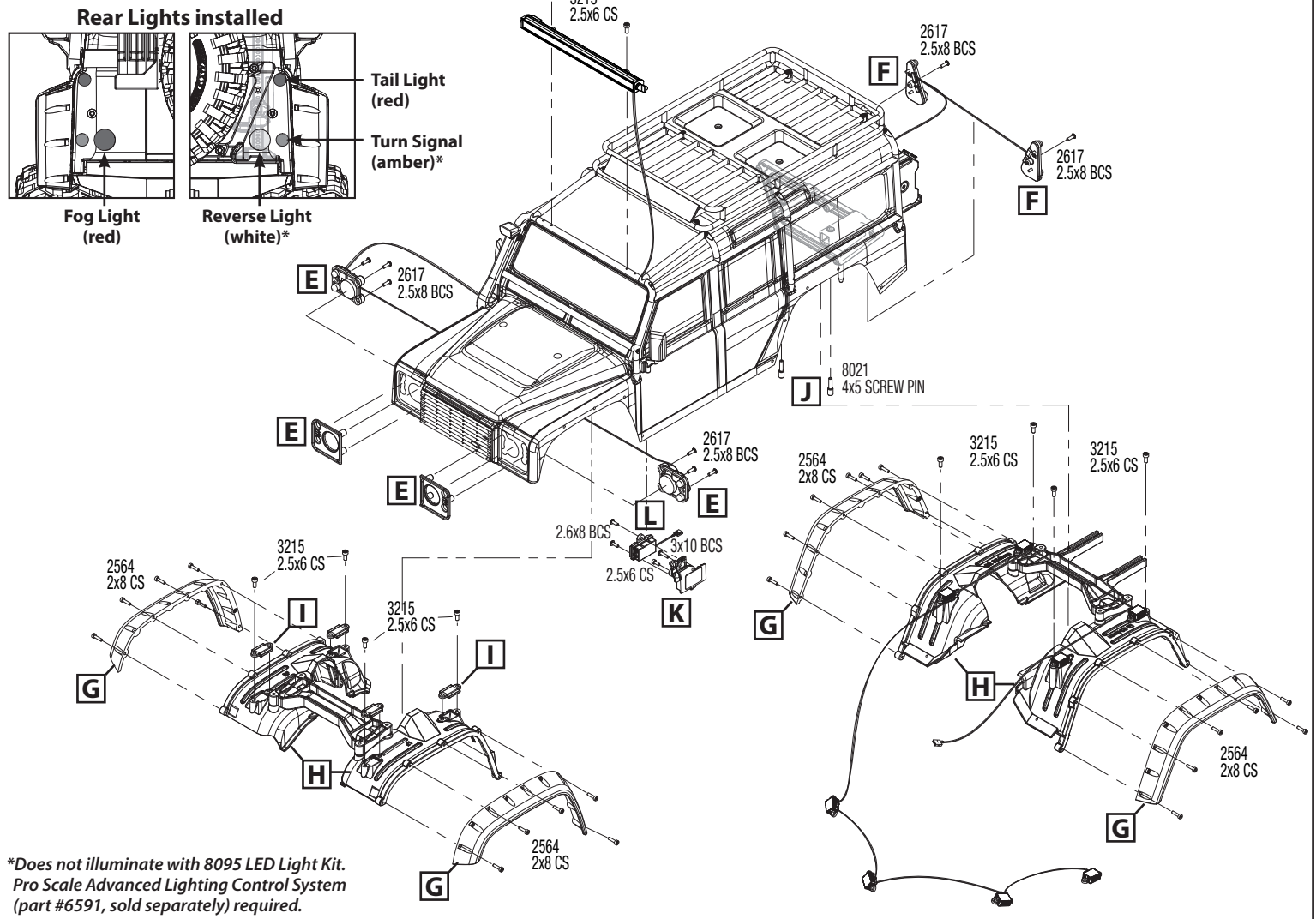

# Wiring Diagram

Fig. 7

